

# 零件目錄

# PARTS CATALOGUE

*Electric Start*

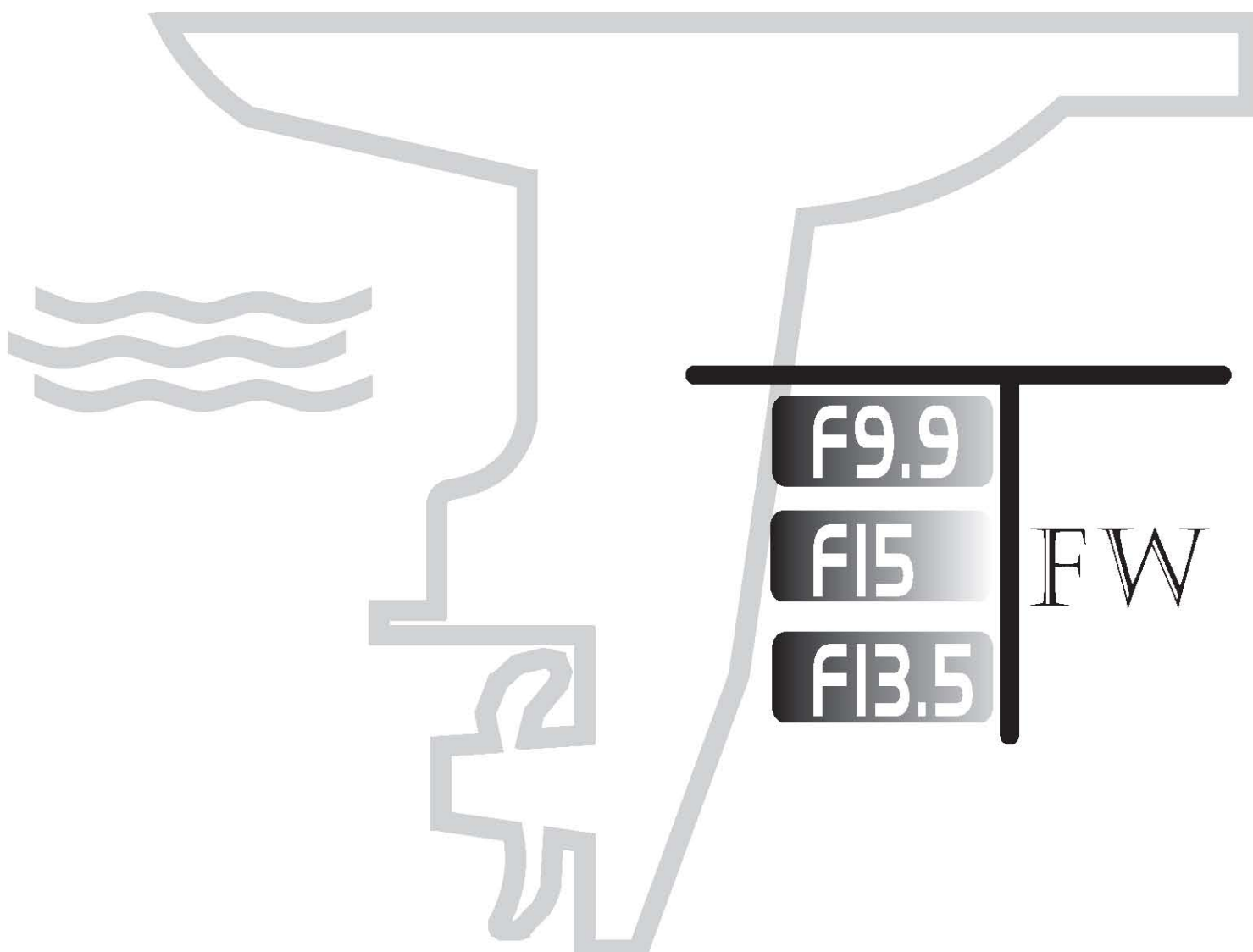

苏州百胜动力机器有限公司

*SUZHOU PARSUN POWER MACHINE CO., LTD*

# 目次

## CONTENTS

进气系统	1
INTAKE	1
电气 1	2
ELECTRICAL 1	2
电气 2	3
ELECTRICAL 2	3
起动机	4~5
STARTER (SUPPLEMENT)	4~5
操纵盒组件	6~8
CONTROL BOX ASSY	6~8
底罩和托架	9~10
BOTTOM COWLING & BRACKET	9~10

零部件名称:

进气系统

PARTS NAME:

INTAKE

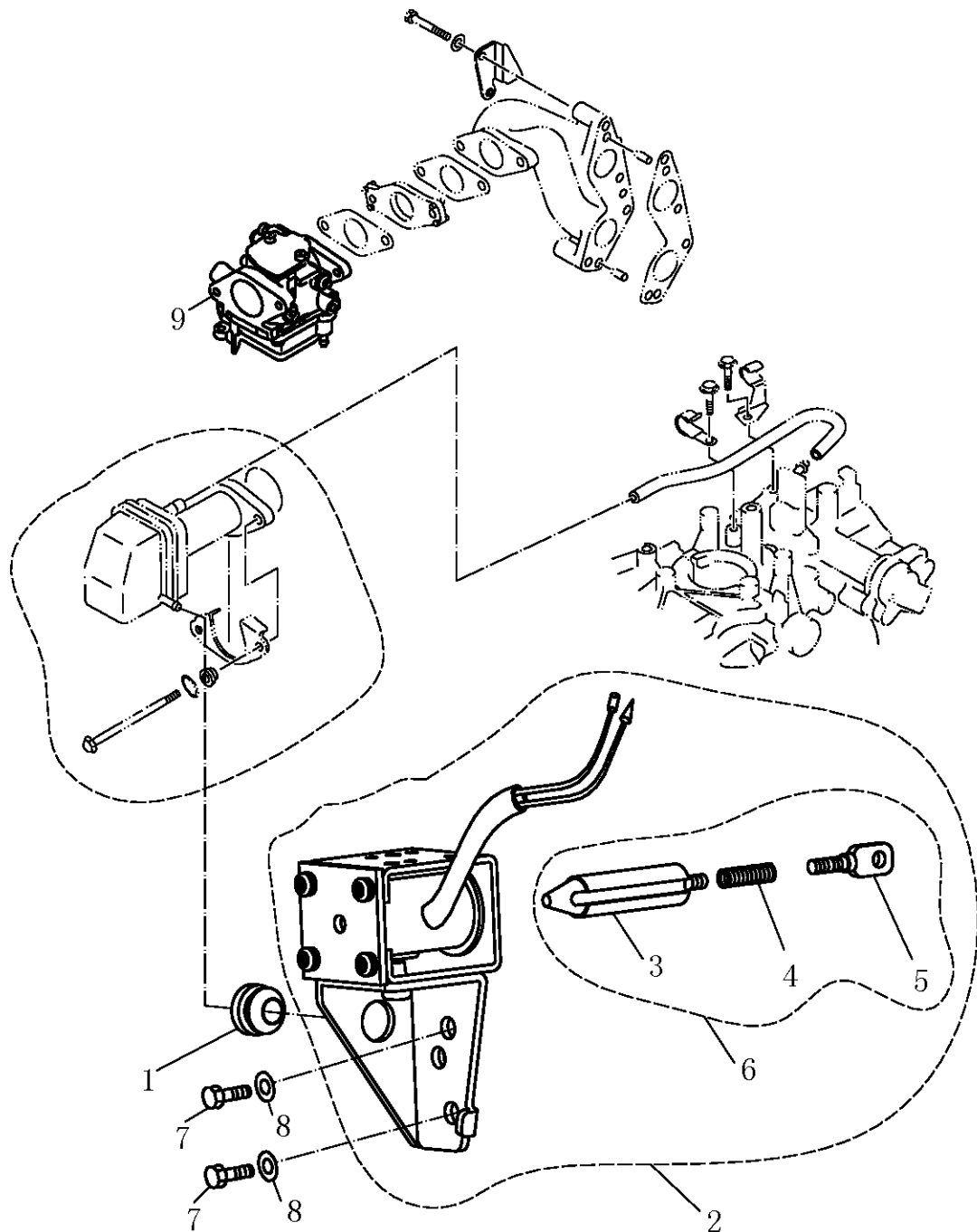

SN. 参照号码	PART NO. 零件编号	DESCRIPTION 零件名称 (中文)	DESCRIPTION 零件名称 (英文)	QTY 数量					REMARKS 备注
1	F4-0200011	变档轴密封圈	SEAL, SHAFT	1					
2	F15-1103000W	电磁吸铁组件	ELECTROMAGNETIC MAGNET ASSY	1					
3	F15-11030301W	铁芯	IRON CORE	1					
4	F15-11030302W	铁芯连杆	LINK RAD, IRON CORE	1					
5	F15-11030303W	铁芯拉头	HOOK, IRON CORE	1					
6	F15-11030300W	吸铁铁芯组件	IRON CORE ASSY	1					
7	GB/T5783-M6X12	六角螺栓M6X12	BOLT, HEXAGON M6 × 12	2					
8	GB/T97.1-6	平垫圈6	WASHER 6	2					
9	F15-07090000W	化油器总成	CARBURETOR	1					

零部件名称:

电气1

PARTS NAME:

ELECTRICAL 1

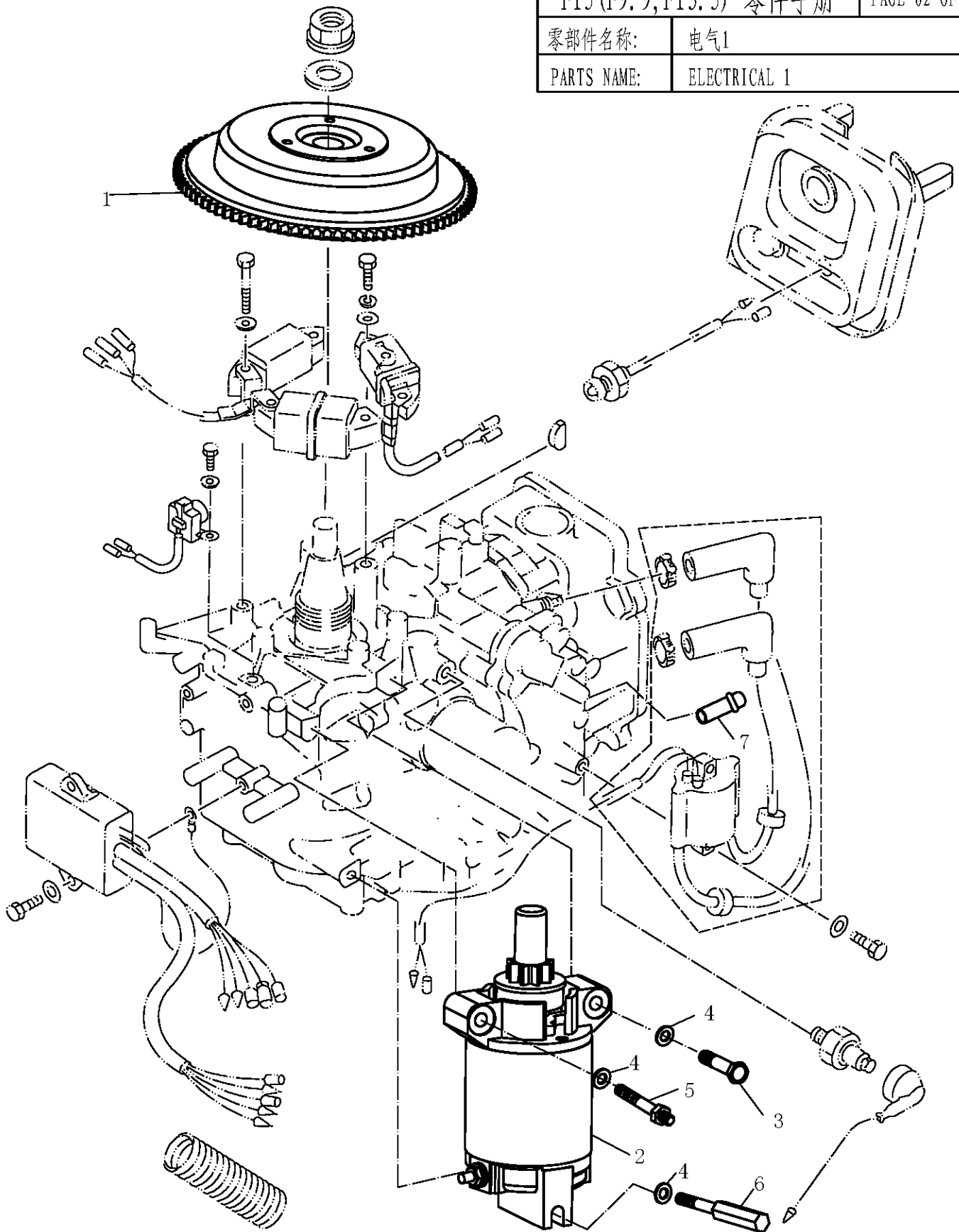

SN. 参照号码	PART NO. 零件编号	DESCRIPTION 零件名称(中文)	DESCRIPTION 零件名称(英文)	QTY 数量					REMARKS 备注
1	F15-07070100W	飞轮组件	FLYWHEEL ASSY	1					
2	F15-07150100W	启动电机	STARTUP MOTOR	1					
3	GB/T5782-M8X50	六角头螺栓M8×50	HEXAGON BOLT M	1					
4	GB/T97.1-8	平垫圈8	WASHER 8	3					
5	F25-05170001W	电机固定螺栓M8	FIXATION BOLT, MOTOR	1					
6	F15-07150002W	柱状螺栓M8	COLUMNAR BOLT	1					
7	F25-05010402W	出水嘴	WATER GAP	1					

零部件名称: 电气2

PARTS NAME: ELECTRICAL 2

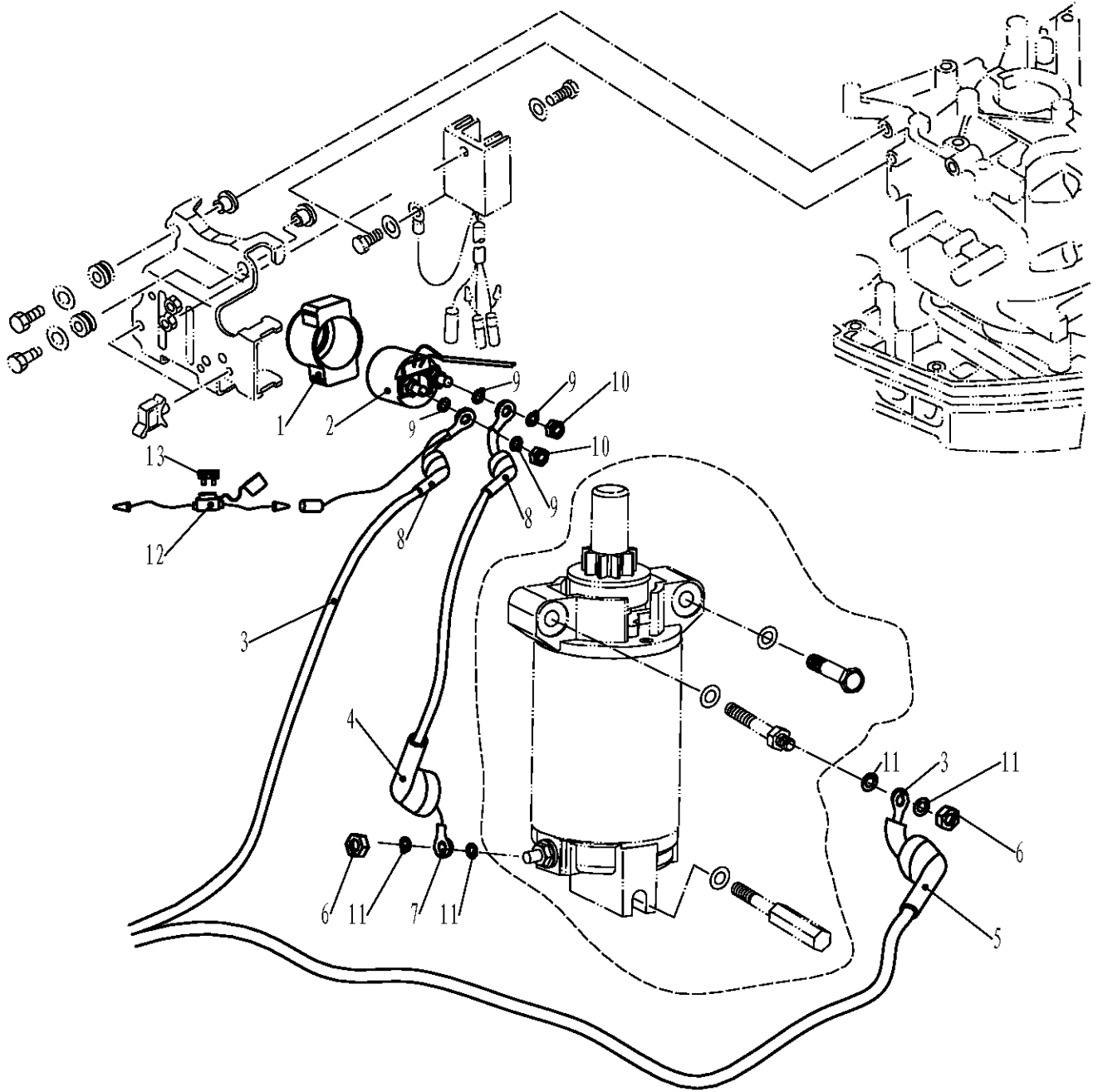

SN. 参照号码	PART NO. 零件编号	DESCRIPTION 零件名称 (中文)	DESCRIPTION 零件名称 (英文)	QTY 数量				REMARKS 备注
1	F15-07150301W	继电器护套	RELAY JACKET	1				
2	F15-07150300W	继电器	RELAY	1				
3	F15-07150200W	电源连接线	LINE, POWER SOURCE	1				
4	F25-05170201W	电源连接线护套A	COVERING A, POWER SOURCE LINE	1				
5	F25-05170202W	电源连接线护套B	COVERING B, POWER SOURCE LINE	1				
6	GB/T6170-M8	六角螺母M8	HEXANGULAR NUT M8	2				
7	F15-07150500W	电机连接线	CONNECTION LINE, MOTOR	1				
8	F15-07150501W	电机连接线护套	JACKET, CONNECTION LINE	2				
9	GB/T97.1-6	平垫圈 6	WASHER 6	4				
10	GB/T6170-M6	六角螺母M6	HEXANGULAR NUT M6	2				HSn62-1
11	GB/T97.1-8	平垫圈 8	WASHER 8	4				
12	F25-05090100W	熔断器组件 (JEF-709J)	FUSE ASSY	1				
13	F15-07150001W	保险丝20A	FUSE	1				

零部件名称: 起动机(补充)

PARTS NAME: STARTER (SUPPLEMENT)

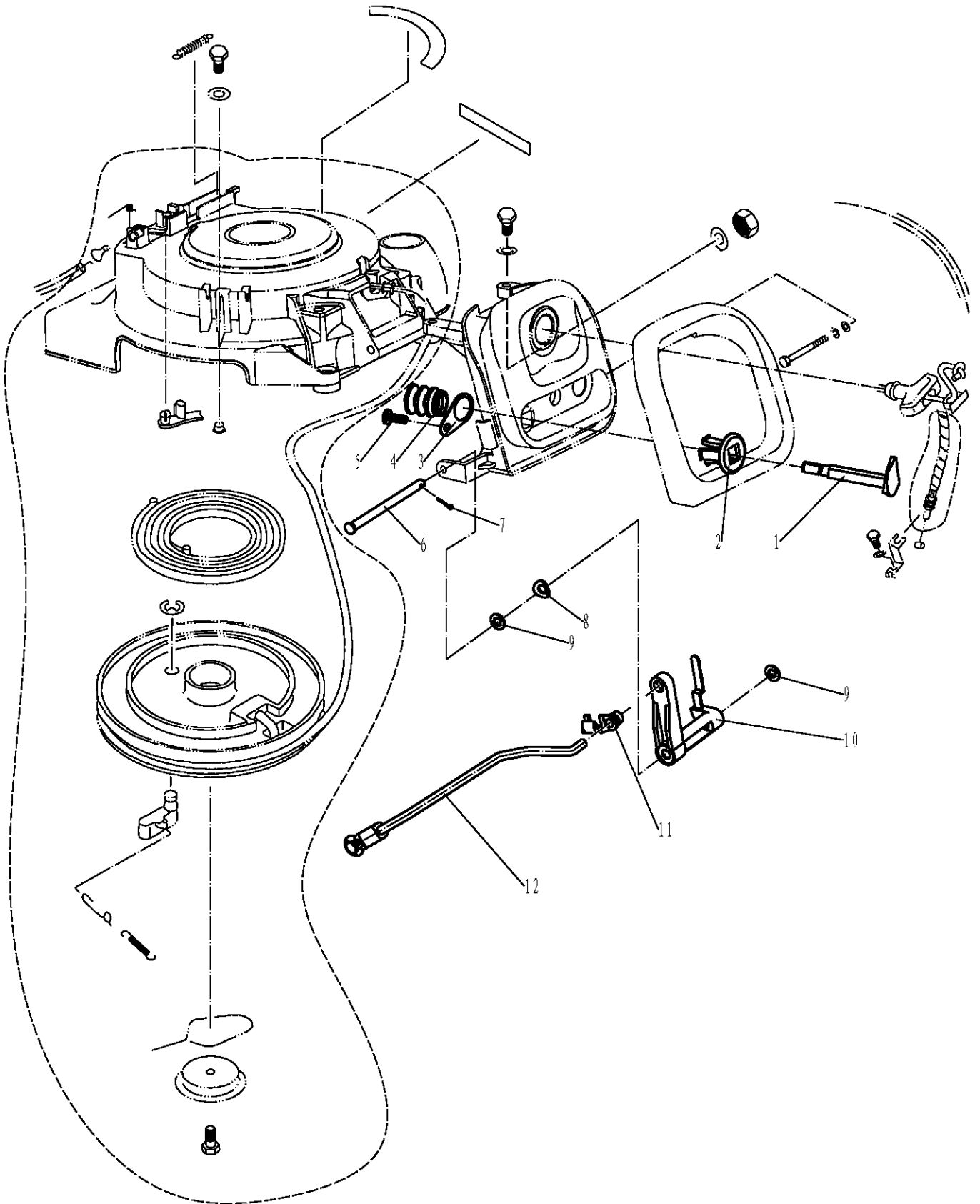



零部件名称: 操纵盒组件

PARTS NAME: CONTROL BOX ASSY

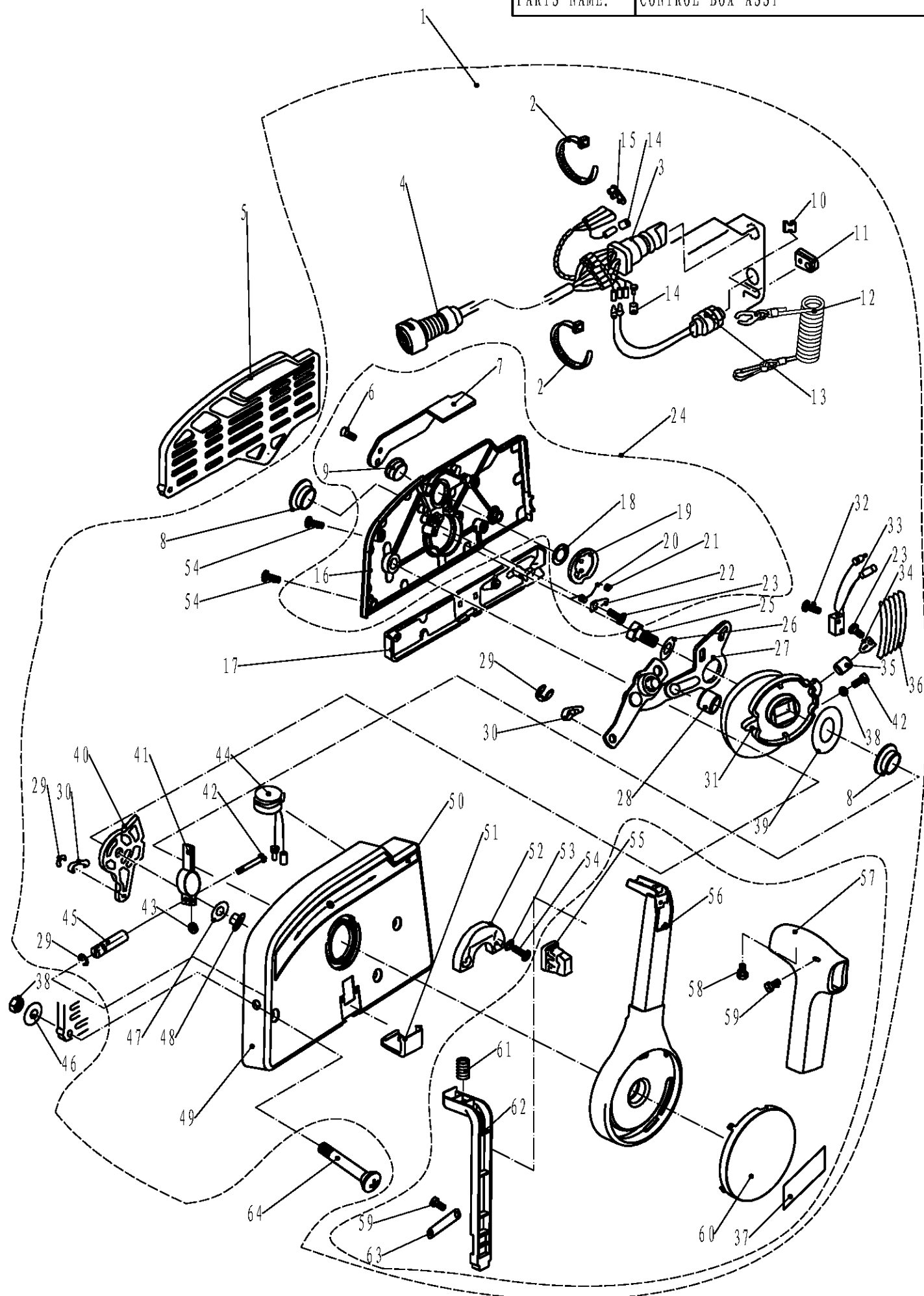



零部件名称:

操纵盒组件

PARTS NAME:

CONTROL BOX ASSY

SH. 参照号码	PART NO. 零件编号	DESCRIPTION 零件名称(中文)	DESCRIPTION 零件名称(英文)	QTY 数量					REMARKS 备注
1	F15-13000000W	操纵盒组件	CONTROL BOX ASSY	1					
2	HT2.5*60	尼龙扎带	CLAMP	2					
3	F15-13000200W	起动开关组件	STARTING SWICH ASSY	1					
4	F15-13000100W	操纵线束组件	CONTROL CABLE ASSY	1					
5	F15-11000002W	操纵盒安装板	PLATE ,CONTROL BOX	1					
6	GB/T819.2-MSX12	十字槽沉头螺钉M5×12	SCREW PAN HEAD M5×12	2					
7	F15-13020007W	油门微调手柄	THROTTLE HANDLE ,INCHING	1					
8	F15-13000005W	凸轮机构衬套	BUSH ,CAM	2					
9	F15-13020006W	微调手柄衬套	BUSH ,HANDLE	1					
10	F15-11000001W	钢索橡胶垫块	BLOCK ,RUBBER	1					
11	F15-13000014W	线索护套	JACKET ,CABLE	1					
12	F4-01090401	引擎停止安全索	STOPER ,HANG ROPE ASS'Y	1					
13	F15-13020400W	急停开关组件	ENGINE STOP SWICH ASS'Y	1					
14	F15-13000203W	绝缘堵头B	INSULATED PLUG "B"	2					
15	F15-13000202W	绝缘堵头A	INSULATED PLUG "A"	1					
16	F15-13020001W	操纵盒盖	COVER ,CONTROL BOX	1					
17	F15-13000013W	操纵盒小盖板	SMALL COVER ,CONTROL BOX	1					
18	F15-13020005W	波形垫圈B	WASHER "B" ,WAVE	1					
19	F15-13020100W	锁紧圆盘组件	LOCKED DISK ASS'Y	1					
20	F15-13020002W	扭簧	TORSION SPRING	1					
21	F15-13020003W	互锁滑轮	EACH LOCKED PULLEY	1					
22	F15-13020004W	滑轮弹簧压板	PLATE ,PULLEY SPRING	1					
23	GB/T818-M4X6	十字槽盘头螺钉M4×6	PAN HEAD SCREW M4×6	2					
24	F15-13020000W	操纵盒盖组件	COVER ASS'Y,CONTROL BOX	1					
25	GB/T5783-M8X30	六角螺栓M8×30	BOLT M8×30	1					
26	GB/T97.1-8	平垫圈8	WASHER 8	1					
27	F15-13000500W	油门控制机构	MACHINE ,CONTROL ACCELEROGRAPH	1					
28	F15-13000007W	销轴垫圈	WASHER	1					
29	GB/T896-6	开口挡圈6	PIN ,COTTER 8	3					
30	F25-07000007W	操纵钢索接头B	CONTROL CABLE TIE-IN "B"	2					
31	F15-13000002W	凸轮机构	CAM MECHANISM	1					
32	GB/T818-M3X14	十字槽盘头螺钉M3×14	PAN HEAD SCREW M3×14	2					
33	F15-13000800W	微动开关	INCHING SWITCH	1					
34	F15-13000003W	档位弹簧片压板	PLATE	1					
35	F15-13000004W	档位滑轮	PULLEY	1					
36	F15-13000001W	档位弹簧片B	SHIFT SPRING PLATE "B"	5					
37	F15-12000016W	标贴16	MARK 16	1					
38	GB/T6170-M6	六角螺母M6	NUT M6	4					
39	F15-13000008W	凸轮机构减磨片	WEARABLE PLATE ,CAM MACHANISM	1					
40	F15-13000700W	变档摆杆	SHIFT SWING LINK	1					
41	F15-13000601W	调节器固定板组件	ADJUSTER FASTNESS ASS'Y	1					
42	GB/T5783-M5X25	六角螺栓M5×25	BOLT M5×25	2					
43	GB/T6170-M5	六角螺母M5	NUT M5	2					



零部件名称:

底罩和托架

PARTS NAME:

BOTTOM COWLING & BRACKET

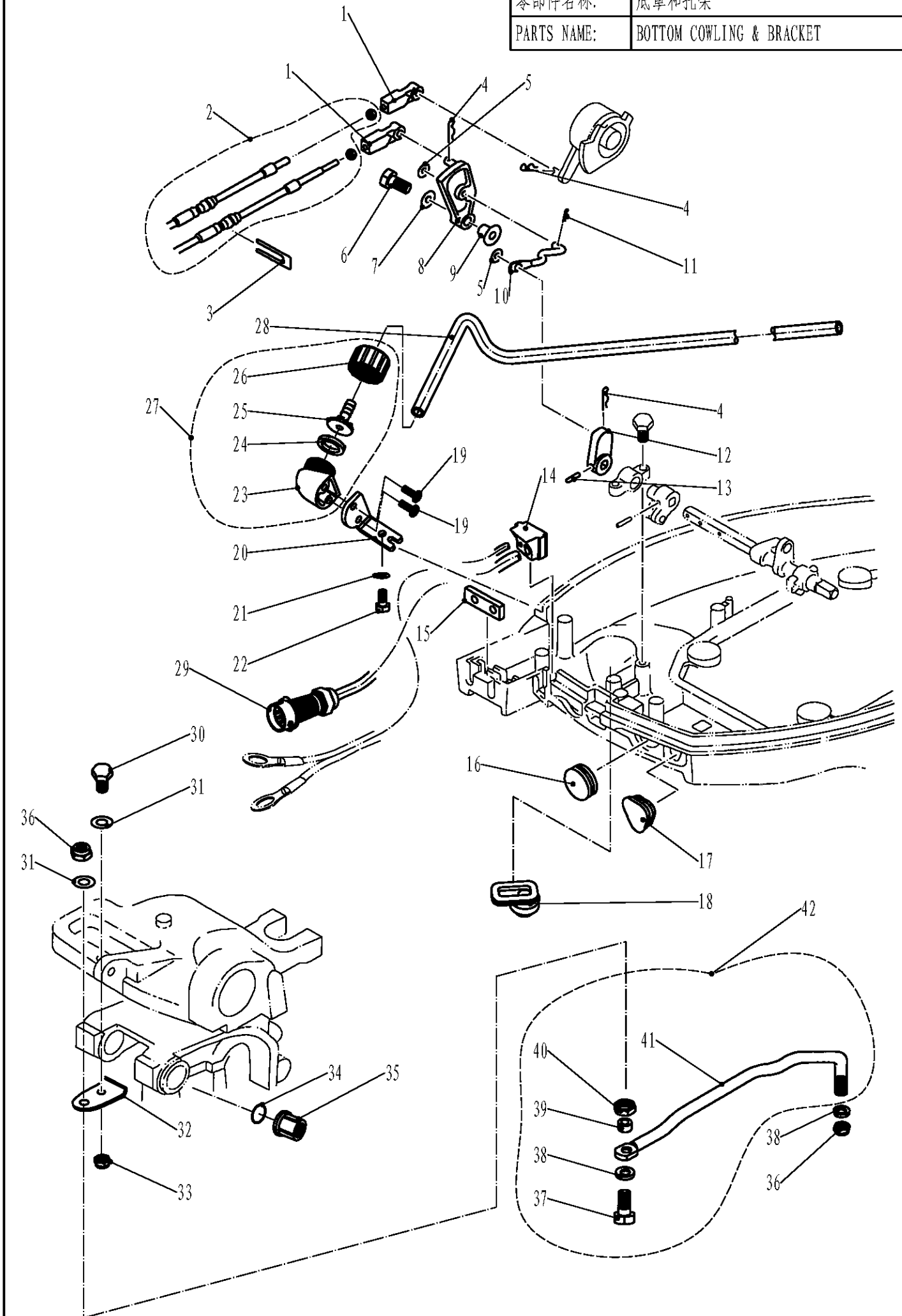

零部件名称:

底罩和托架

PARTS NAME:

BOTTOM COWLING &amp; BRACKET

SH. 参照号码	PART NO. 零件编号	DESCRIPTION 零件名称 (中文)	DESCRIPTION 零件名称 (英文)	QTY 数量					REMARKS 备注
1	F25-07000005W	操控钢索接头A	TIE-IN , CONTROL CABLE	2					
2	F15-11010000W	操控钢索组件	CONTROL CABLE ASS'Y	1					
3	F25-07000003W	开口限位板	PLATE ,RINGENT	1					
4	F15-00000012	夹簧φ1.8	SPRING	3					
5	GB/T96-5	大垫圈5	BIG WASHER 5	4					
6	GB/T5783-M6X25	六角螺栓M6×25	BOLT M6×25	1					
7	GB/T5287-6	特大垫圈6	BIG WASHER 6	1					
8	F25-03000027W	变挡限位板	PLATE ,SHIFT	1					
9	F25-03000028W	限位板衬管	BUSH ,LIMITED PLATE	1					
10	F15-05040103W	变挡连接杆	LINK ROD ,SHIFT	1					
11	F25-05160002	夹簧φ1	SPRING	1					
12	F25-03030003W	制动器摇臂B	ROCKER ,STOPPER	1					
13	GB/T879.2-3X20	轻型直槽弹性圆柱销φ3×20	COLUMNIFORM PIN φ3×20	1					
14	F15-03000013W	异形橡胶堵头	JAM ,ABNORNOMITY RUBBER	1					
15	F25-03000029W	长方形橡胶密封条	JAM ,RECTANGLE	1					
16	F25-03000024W	圆形橡胶闷头B	JAM "B"	1					
17	F25-03000025W	油门钢索堵头	JAM ,ACCELEROGRAPH CABLE	1					
18	F25-03000022W	水管波纹护套	BUSH ,WAVE	1					
19	GB/T84.5-ST5.5X19	十字槽盘头自攻螺钉ST5.5×19	SCREW ,PAN HEAD ST5.5×19	2					
20	F25-03000023W	堵塞支架	BRACKET	1					
21	GB/T5783-M6X20	六角螺栓M6×20	BOLT M6×20	1					
22	GB/T97.1-6	平垫圈 6	WASHER 6	1					
23	F25-03000101W	堵塞本体	JAM	1					
24	F25-03000102W	堵塞橡胶圈	BUSH ,RUBBER JAM	1					
25	F25-03000103W	堵塞接头	TIE-IN , JAM	1					
26	F25-03000104W	堵塞螺母	NUT , JAM	1					
27	F15-03000100W	堵塞组件	JAM ASS'Y	1					
28	F25-03000021W	定型水管	WATER TUBE	1					
29	F15-07150400W	点火线索组件	C. D. I. CABLE ASS'Y	1					
30	GB/T5783-M8X30	六角螺栓M8×30	BOLT M8×30	1					
31	GB/T97.1-8	平垫圈8	WASHER 8	1					
32	F15-11020003W	转向连接板	PLATE	1					
33	GB/T6170-M8	六角螺母M8	NUT M8	1					
34	JASO F404-24-016	O形密封圈	O-RING	1					
35	F25-01010012W	塑料装饰螺母B	NUT ,PLASTIC	1					
36	F25-07000006W	非金属嵌件六角锁紧薄螺母3/8"	THIN LOCKNUT	2					
37	F15-11020002W	转向连杆螺栓	BOLT	1					
38	GB/T97.1-10	平垫圈10	WASHER 10	2					
39	F25-07000303W	螺栓垫管	TUBE ,BOLT	1					
40	F25-07000304W	六角螺母3/8"	NUT	1					
41	F15-11020001W	转向连杆	LINK ROD , TURNING	1					
42	F15-11020000W	转向连杆组件	LINK ROD ASS'Y	1					